

# CONNECT 39

Thorsby, Warburg & Area NEWS

previously the Thorsby Target & Warburg Bugle

## WARBURG HERITAGE DAYS 2023

presented by the Warburg Pioneer Ag Society

### SCHEDULE OF EVENTS SATURDAY, JUNE 24

#### 8:30-10am – Pancake Breakfast

At the Community Hall  
(Village Council & Staff/Pioneer Ag Society) \$5

#### 11am-3pm – “Party in the Park” (Warburg Community Park)

- Entertainer - Gregory Baldwin
- Puppet Show (Friends Forever Puppets)
- Bathtub Races (3-D Line Locating)
- Money Pit (Direct Line Insurance)
- Log Sawing (Pioneer Ag Society)
- Show & Shine (Joanne Liba)
- Nail Pounding (Mercon Construction)
- Petting Zoo (Finnigan Farms)
- Kids Corner (FCSS)
- Children Activities (Leduc County)
- Market (CL Country Market)
- Concession (Grade 11 class)
- Sno Cones/Cotton Candy (FCSS)
- Pies (Warburg Museum)
- Ice Cream (Two B's Flowers & Bistro)
- Food Trucks - Haimees Mini Donuts; Out West Bites; Garfield & Odies Sugary Treats; Lotza Motza

#### 1-5pm – Beer Gardens in the Park (Warburg Curling Club)

3pm – Bike decorating time!  
(some decorations will be provided) Place-TBA

4pm – Bike parade starts!  
Place- TBA

5-7pm - Supper  
At the Community Hall (Breton Royal Purple/Elks)  
Pulled pork on a bun, baked potato, coleslaw  
(Advance tickets \$10 each, Purchase tickets at the door \$15 each)

7pm - Parade  
(West of Arena - entrants must be lined up and ready by 6:30pm)

9pm-1am - Dance “Black Water Crude”  
At the Community Hall (Warburg Legion)  
Doors open at 8pm, dance starts at 9pm (\$20)  
Concession available (Warburg Cultural Centre)

MIDNIGHT – FIREWORKS!!  
At the Ball Diamonds

### WARBURG PARENT SCHOOL SOCIETY 50/50 CASH RAFFLE

**CASH PRIZE UP TO \$10,000!!**

**\$10 per ticket (only 2,000 available)**

Go to [www.rafflebox.ca/raffle/warburg-pss](http://www.rafflebox.ca/raffle/warburg-pss). Tickets available until June 23, 2023, Same day draw at 1pm at Warburg School.

The proceeds will be used to purchase items such as sports, playground, audiovisual equipment plus science, art and technology supplies, and to provide additional programming opportunities by funding or subsidizing the costs



Bathtub Races 2022



Log sawing in the park 2022

# Classifieds

## FOR RENT

**1650 SQ. FT COMMERCIAL BUILDING** with Mezzanine on Hankin Street in Thorsby for Rent, Contact Grant 780-446-1596

## FOR SALE

Boxford Denfords Screw Cutting **METAL LATHE** Model No. ME 10/A, \$2000, Phone 780-789-0123

Breton West Herefords has both **HORNED & POLLED BULLS** for sale. Call or text Leonard at 780-898-9590

## WANTED

**LEAD BATTERIES & SCRAP VEHICLES** Will buy your old lead batteries for re-cycling. Also **FREE** removal of scrap vehicles. We pay cash for both! 403-396-8629

## OLD FARM TRACTORS OR CATERPILLARS

Will buy Complete or Incomplete. 403-396-8629

## WANTED CONCRETE RUBBLE

Contact Alex 780-905-9200 or 780-789-3843

## SERVICES

**JOURNEYMAN PLUMBER/GASFITTER & CERTIFIED SEWER INSTALLER** Repairs, replacement & new installs. Hot water tanks, furnaces, boilers, gas lines, sewer tanks/fields/pumps. Ryan 780-514-9246

## D5 DOZER FOR HIRE

Contact Alex 780-905-9200 or 780-789-3843

**RELIABLE DJ** for your party or special event. We offer Karaoke, Music Bingo, Minute to Win It games and have local references. 587-991-4977 or [www.carrievins.com](http://www.carrievins.com)

**INTERIOR DESIGN, CABINETS, COUNTERTOPS & BLINDS.** Independent Design Consultant for over 25 years. Keri at [designbywaters@live.ca](mailto:designbywaters@live.ca) or 780-289-2551. Also on Facebook and Instagram!

**FULL-SERVICE BOOKKEEPING & PERSONAL TAX SERVICES** Check out [jensbookkeepingservices.ca](http://jensbookkeepingservices.ca) for a full list of services. Call Jen at 780-898-5198 or email [jensbookkeepingservices@outlook.com](mailto:jensbookkeepingservices@outlook.com)

**Classified Ads are \$7.50 for 2 weeks (up to 30 words) GST included**

You can drop off your ads at the **Warburg Town Office** or **CE MEDIA - 4928 Hankin Street Thorsby** 780-499-9006 or email to [media@community39.com](mailto:media@community39.com)

Connect 39 can be viewed online & in color at [www.community39.com](http://www.community39.com)

If you'd like to get a link to the paper in your inbox you can subscribe online or email [media@community39.com](mailto:media@community39.com)



*Trucking*  
WARBURG AB.

Ph. 780.848.7668

Wilf Brandt Trucking Ltd. is currently hiring:

- **Experienced Class 3 Tank Truck Drivers** (experience with Vac Truck is beneficial)

- **Experienced Swamper** to work on Vac Truck

*These units are working in Warburg, Sunnybrook, Leduc & Surrounding Areas.*

*Must have Current oilfield tickets and clean abstract, Pre-employment screening will be required.*

*Benefits are available. Accommodations are not provided.*

Email resumes to: [resumeswbt@gmail.com](mailto:resumeswbt@gmail.com)

## Family Mediation Centre of Canada

- Division of Assets
- Parenting Time
- Decision Making
- Support Obligations

MIKE PETRACEK

Family Mediator

780-515-0922 [mike@fmcoc.ca](mailto:mike@fmcoc.ca)

[familymediationcentreofcanada.ca](http://familymediationcentreofcanada.ca)



**Knock the Fight out of Divorce**

"Little papers...BIG RESULTS"

4	5	2	9	8	7	6	1	3
8	6	3	4	1	5	9	7	2
9	7	1	2	3	6	4	5	8
5	2	6	8	9	1	7	3	4
3	8	7	6	5	4	1	2	9
1	9	4	7	2	3	5	8	6
7	3	8	1	6	9	2	4	5
2	4	9	5	7	8	3	6	1
6	1	5	3	4	2	8	9	7

Sudoku Answers  
from June 16 Issue

*The object of the puzzle is to fill the remaining squares, using all the numbers 1-9 exactly once in each row, column, and the nine 3 x 3 subgrids.*



# NOW HIRING

Frontier Construction Products is hiring a **YARDMAN TRAINEE** at our Thorsby office. You would be required to work individually, but also as part of a team to provide exceptional customer service. Your responsibilities would entail a variety of duties such as (but not limited to) packaging & shipping orders, shipping/receiving, operating various yard equipment such as forklifts and small power tools, and other general yard duties in all types of weather.

**We are looking for:**

- forklift certified is an asset, we can provide training
- shipping/receiving experience is an asset
- labour and power tool experience is an asset
- strong customer service focus
- be physically fit (bend, crouch, kneel, handle heavy loads, fast paced environment, work outdoors)
- excellent communication, both written and verbal
- team player, mature, responsible
- ability to follow direction

Email to: [careers@frontier-cp.com](mailto:careers@frontier-cp.com)



## Employment Opportunities

Casual basis Guard positions with the Commissionaires at the RCMP Detachment in Thorsby/Breton.

Guards/Matrons are responsible for the monitoring and well-being of prisoners while in the care of the Police.

Applicants must pass an RCMP clearance, be capable of working independently, do shift work, must be available for shifts on a casual basis and able to legally work in Canada

First Aid and CPR is an asset.

Please call to inquire:  
780-789-3951 / 780-696-3520



## COME JOIN OUR TEAM!!

We are looking to hire casual & part-time Healthcare Aides & Personal Support Workers

**REQUIREMENTS:**

- Current CPR and First Aid
- Graduate of HCA program
- Strong oral communication and time management
- Experience in caregiving with seniors or individuals with disabilities
- Dedicated to providing, compassionate and dignified care while encouraging the independence of the client.

Contact Sherrie for more information at  
**(780) 905-9917**

Accepting resumes at  
[hello@kindredcarehomeservices.com](mailto:hello@kindredcarehomeservices.com)

## THE WARBURG LEGION PRESENTS



KICK-OFF TO SUMMER PARTY



FEATURING!



# BLACKWATER CRUDE

Warburg Community Hall  
Saturday, June 24th, 2023 - Warburg Heritage Days

Tickets - \$20

Doors Open at 8pm

Dance 9pm to 1am

**NO MINORS**

Tickets Available at:  
Breton Tires & Tow  
Warburg Village Market  
Christina - 780.689.0865  
Iris - 780.514.8397





www.mikeshomesltd.com

# COMMUNITY EVENTS & info

## UPCOMINGSPECIAL EVENTS (Breton, Thorsby, Warburg & Surrounding Areas)

**MORROWDALE - Cemetary Service** on Friday **June 23** at 6:30pm at Morrowdale **CANCELLED** Potluck Supper.

**WARBURG Annual Heritage Day** on **June 24**. Pancake Breakfast, Party in the Park 11am-3pm, Beer gardens, Supper 5-7pm, Parade 7pm, Dance 9pm-1am, Fireworks @ Midnight.

**WARBURG Legion Heritage Day Dance** on **June 24** featuring Blackwater Crude. 8pm - 1am at the Warburg Community Hall.

**THORSBY - St. John The Baptist Ukrainian Catholic Church, Divine Liturgy and Grave Blessing** on Saturday, **June 24th** @10:30am. More info please contact Dan @ 780-789-3698

**WARBURG - Free Welcome to Summer Pancake Breakfast Sunday, June 25**, 9-11:30am at the Warburg Adventist Church, 5003-48 Street. Open to all, games for children and more.

**SANDHOLM - Pancake breakfast** at Sandholm Hall (corner 616x and hwy 778) on **Sunday, June 25, July 30 & August 27** from 8am to 11am. For information call 780-389-2381

**WARBURG Welcomes Circus Wonderland June 28**, Shows 4:30pm & 7:30pm @ District Memorial Arena. Buy tickets online [www.circuswonderland.net](http://www.circuswonderland.net). Online discount code: MAGIC

**GLEN PARK Community Assoc** is hosting a **55+ free lunch & entertainment June 28 at 5pm**. \$2 in advance so caterer is prepared. Call 780-919-1250

**BRETON - 2023 Golden Spur Gymkhana Buckle Series** on **June 29, July 13, 27, Aug 10, and 17** (Finals). Gates @ 6pm, Starts @ 7pm. Email: [goldenspurgymkhana@hotmail.com](mailto:goldenspurgymkhana@hotmail.com)

**MULHURST - Royal Canadian Legion Mulhurst #246** hosts **Community Socials Friday, June 30th** at 7pm.

**BRETON - Canada Day July 1st in Breton**. Parade, Vendor Market, Show n' Shine, Children's Activities, and more...

**CENTRELODGE** is hosting a **Canada Day Pancake Breakfast** on **July 1**, 8:30am - noon. Fun for the kids, raffle. Everyone Welcome! 6 miles S and 1-1/4 miles E of Thorsby

**BRETON - Babysitters Course** on **Monday, July 10** for youth ages 11 & older. Contact Breton FCSS for more information.

**WINFIELD Lions Club Monthly Dance** on **July 2, August 11** from 1-4pm at the Winfield Recreation Centre. Live Band - No Hitchhiker, \$7 per adult, kid's free.

**WARBURG Vacation Bible School** - July 10-14 from 9-11:30am at the Warburg Alliance Church. 5yrs to Grade 6. FREE, to register call Eva Hubscher 780-696-2482

## Custom Built Homes

- Reliable Service
- Affordable Pricing
- Quality Workmanship



"You Dream It – We Build It!"

**MICHAEL JACOB**  
780.991.1008

[michaelj@mikeshomesltd.com](mailto:michaelj@mikeshomesltd.com)

**BRAZEAU - ALUS Free Bus Tour** on **July 12**, register at [www.alusbrazeautour.eventbrite.ca](http://www.alusbrazeautour.eventbrite.ca). Must register by July 5.

**WARBURG Bloomin Buddies Garden Tour 2023, July 15 & 16**. Tickets \$50 (Includes lunch, refreshments, tour & prizes for 1 day). Call Linda at 780-966-2045 for tickets.

**STRAWBERRY Hall - Senior afternoon concert** on **August 9**

**SUNNYBROOK - 100th Anniversary** on **August 12**. Parade, Party in the Park, Supper, Dance, Fireworks, Market and more... Email [sunnybrookcommunityhall@gmail.com](mailto:sunnybrookcommunityhall@gmail.com)

**LEDUC COUNTY - A Taste of Leduc County**, Farm to Table Dinner, Bus Tour & Market. Saturday **August 12** from 12-9pm. Tickets online at [www.theoldredbarn.ca/events](http://www.theoldredbarn.ca/events)

**BRETON - Ladies Golf Tournament** on **August 17**. Register by July 15 with Lorraine 780-292-2737 or Deb 587-989-2281

**BRETON Vacation Bible School** - August 21-26, K to Grade 6, Faith Covenant Church. Call 780-696-3669 to register

**THORSBY - Lone Wolf Presents Car & Truck Show n' Shine** on **August 26** from 10am - 5pm. Mega Trucks, car crushing, tug-a-war, family friendly activities and more...

*A Full Community Connections listing is in once a month. Last listing was in the June 2 issue. This includes community group contacts, facilities for rent, churches and other local information. Get this information anytime at [www.community39.com](http://www.community39.com)*

**The CE Media Signs & Promotional / Community 39 Office will be CLOSED on June 30 for Canada Day**



**Happy Canada Day!**



RECREATION COMPLEX

Thank you



Thank you to Ruhr Valley Lumber for donating the materials to replace the seating and stairs for the baseball bleachers at the Arctic Spas Recreation Complex



# Give back. Get paid. Make a difference.



Leduc County is accepting applications for paid on-call firefighters!

Become a paid on-call firefighter in the Calmar, New Sarepta, Nisku, Thorsby or Warburg fire districts.

Learn more and apply at [leduc-county.com/recruitment](http://leduc-county.com/recruitment) or call 780-955-7099.

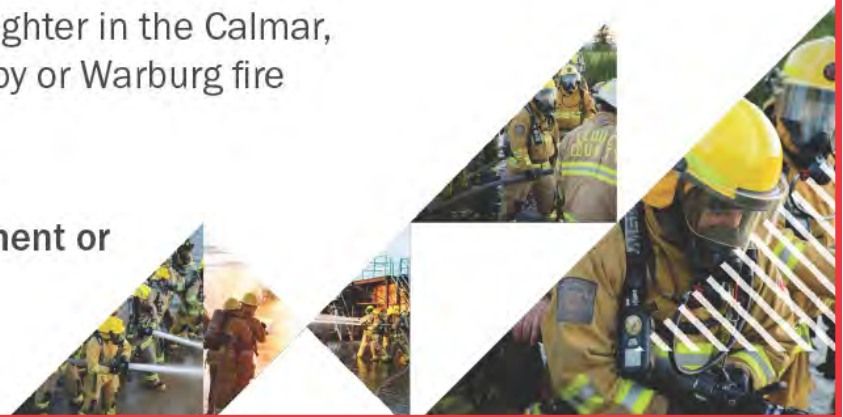

**PROGRAMS & REGULAR EVENTS**  
(Breton, Thorsby, Warburg & Surrounding Areas)

**BRETON Baby & Me** for mom's with baby's under 18 mths -1st & 3rd **Thursday mornings** from 10-11:30am at the Breton Community Centre. Contact [fcss@breton.ca](mailto:fcss@breton.ca) or 780-696-3636

**BRETON Book Club** - meets at the Library the **second Wednesday** of the month at 7:30pm from September until June. All readers are welcome to join the conversation!

**BRETON Children's Gym Time** - FREE Drop in for 0-6 years old on **Tuesdays** from 10am -11:30am at the Breton Faith Covenant Church. Hosted by Brighter Futures - 780-514-5070

**BRETON Golden Age Club - Crib** on **Saturdays @ 12:30pm / Floor Curling on Tuesdays @1pm**. Drop in fee \$3. / **Cards on Mondays @1pm**. Drop in fee \$3. Contact Pat at 780-898-1651

**BRETON Golf Course - Men's Night** at 6:30pm (every **Monday**) & **Ladies Night** at 6:30pm (every **Tuesday**)

**BRETON Golf Course - Junior Golf Program** for ages 7 & over on **Wednesdays** (weather permitting) from **4-5:30pm** until the end of August. 780-696-3531 or email [golf@breton.ca](mailto:golf@breton.ca)

**BRETON Kids Klub** - After School Program **Wednesdays** from 3:15-4:45pm for ages 6-12. No fees. Limited spaces. Pre-registration required. Forms at the Library or FCSS office.

**BRETON Low Impact Exercise Class - Wednesday mornings** from 10 - 11am at the Breton Community Centre. \$2 per class. Contact [fcss@breton.ca](mailto:fcss@breton.ca) or 780-696-3636

**BRETON Youth Centre** - Youth Ages 12-17. Open **Tuesdays, Thursdays & Saturdays** - times depend on volunteers. Contact [bretonyouth-center@gmail.com](mailto:bretonyouth-center@gmail.com) or 780-202-0635

**BUCK CREEK** Community Association **Jam Dance & Cards Night** the **first Friday** of every month.

**CALMAR - Seniors Music Jam Session 4th Tuesday** of the month @ 1pm with light refreshments. 4916 - 50 Ave

**MULHURST - Family Bingo's** every **Tuesday @ 6:30pm** at the Royal Canadian Legion #246.

**MULHURST** - Royal Canadian Legion Mulhurst #246 hosts **Community Socials** on the **Last Friday** of the month at 7pm.

**SANDHOLM Square Dance Club** - Youth, couples & singles **Thursdays, 7 - 9:30pm** at the Sandholm Hall (10 miles S of Thorsby). For info call 780-238-5844 or 780-389-2381.

**THORSBY - LEGO Club Monday's** after school 3:30-4:30pm. Come join us for an hour of Lego building! Free drop-in program ages 7+, 6 & under accompanied by parents

**THORSBY - Fun with Friends Storytime** (for preschool) on **Friday's** at 10:30am in the Library

**THORSBY** Lions Club hosting a **Pancake Breakfast first Sunday** of the month at the Senior's Centre 9am - 12pm. For more info call Mercedes King 587-338-7065

**THORSBY Parent & Tot Drop In Program** on **Thursdays** from 10-11am at the FRN Site (Modular next to the Arctic Spas Rec Complex) Fun games, activities & making new friends

**THORSBY Pickle Ball** on **Tuesday & Thursday morning** 9:30am to 11:30am and **Thursday nights** from 7-9pm at the Arctic Spas Recreation Complex. \$5 drop in fee

**THORSBY Seniors Centre - Bingo** every **Thursday evening** starting at 7pm. **No BINGO July & August** and will resume September 7 / **Afternoon Crib every Monday** at 1:30pm. / **Soup & Sandwiches** starting at 11:30am on the **2nd Wednesday** of each month / Everyone welcome!

**WARBURG - Beach Volleyball** - Every **Wednesday** from 6-8pm at the Community Park.

**WARBURG - Busy Brushes** meet on **Wednesdays** at 10 am at the Warburg Cultural Centre. Call Linda at 587-590-0378.

**WARBURG - Games in the Park** - Every **Thursday** at the Community Park (weather permitting)

**WARBURG Pickleball Thursdays** from 6-8pm \$2 each. Warburg School Gym. Equipment provided, no experience needed. Register at the Village office or call 780-848-2828

**WARBURG - Pie & Coffee** from 1pm - 4pm at the Warburg Museum on the **first Saturday** of every month

**WARBURG Seniors Centre - Cards** at 1pm every **Wednesday / Soup & Sandwiches** every **3rd Wednesday** at 12pm \$10 / **Quilting on Tuesday & Thursdays** at 9:30am \$2

**WARBURG - Sew Heavenly Quilters** meet **Thursdays** at 10am at Warburg Cultural Centre. Call Peggy 780-789-2545

**WARBURG - Songs For Toddlers** at the Warburg Library on **Wednesdays** at 1pm at the library.

**WARBURG Saturday** at the Library is **Craft Fun Day**, with a table full of supplies to create a craft for a special day that month

**WARBURG Volleyball** drop in at Warburg School on **Tuesdays from 6-8pm**

**MARKETS/THRIFTSHOPS(NONPROFIT)**

**Thorsby CL Country Market** from 11am - 3pm **June 24** at Warburg Heritage Days. **Sept 16, Nov 18** at Thorsby Rec Complex from 10am-3pm. Email [clsoapco@hotmail.com](mailto:clsoapco@hotmail.com)

**Mulhurst Bay Farmer's Market** at the Mulhurst Bay Community Hall (3802 50 Ave) every **Saturday** 10-2pm. Contact Carol 587-920-2065 for more info.

**Thorsby Seniors Thrift Store** - Open **Thursdays and Fridays** 10am-3pm. Call 780-996-5131. Starting July 8 we will also be Open Saturdays for the summer!

**Warburg Treasure's Thrift Shop** **Wednesdays** from 10am - 4pm. 5112 - 53 Street, Warburg

**Calmar Market on Main** - is hosting markets in Main Street Park on **Fridays from 4-8pm** from May until September. Email [calmarmarket@gmail.com](mailto:calmarmarket@gmail.com) or follow on FB

**Community Events & Information is FREE to advertise**



**Thorsby Seniors Crib Results!**

**June 19th Crib Scores:**

1st - Jackie Pomerleau - 929

2nd - Cathy Dahl - 929

3rd - Brenda Lickoch - 921

High Hand of 24 was held by Dora Shier

**CONGRATULATIONS LADIES!**

**Next crib event will be held on June 26th, Monday 1:30pm, Thorsby Seniors Center**

**Admission \$6**

**Come and joy the fun!**



# SUNNYBROOK HALL 100th Anniversary

Join us in celebrating on  
**August 12, 2023**



## PARADE (starts at 11am)

All are welcome, please register!

*followed by:*

## PARTY IN THE PARK

Games for all ages, Face painting, Sparkly Tattoos and a Magician  
BBQ hosted by Thorsby Communities in Bloom  
Cotton Candy and Donuts by Coffee Pucks & Poutine

## SHOW & SHINE

All are welcome / \$10 Entry  
Cash prize by fan favourite

## GARAGE SALE

## LOCAL CRAFT & FARMERS MARKET

No charge, bring our own table

Pending on permits,

Registration Required by July 15th

## SUPPER AND DANCE

Doors open at 5:30pm, Supper at 6:30pm  
Catering By Ol' Smokie, Cash bar, Door Prize  
Tickets are now on sale for \$20 each  
Please Purchase tickets by August 5.

## FIREWORKS (weather pending)



To register for the Parade and/or Market text Nadine at 587-920-6917  
Or Email [Sunnybrookcommunityhall@gmail.com](mailto:Sunnybrookcommunityhall@gmail.com) or [nadinelange1977@gmail.com](mailto:nadinelange1977@gmail.com)  
For Supper & Dance tickets please call or message Janet 587-986-9031

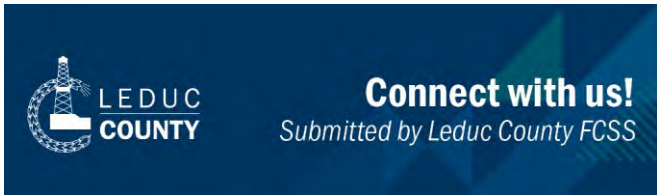

Sign up to receive our monthly update directly to your email inbox. Send an email to [fcssinfo@leduc-county.com](mailto:fcssinfo@leduc-county.com) and ask to subscribe to our email distribution list.

**Emergency preparedness: what you can do?**

Leduc County encourages all residents to be prepared for disasters. Recent wildfire events have required some residents to evacuate. Would you be prepared to evacuate quickly?

- Make an emergency plan. <http://www.alberta.ca/make-an-emergency-plan.aspx>
- Build an emergency kit. <http://www.alberta.ca/build-an-emergency-kit.aspx>
- Stay informed. Download the Alberta Emergency Alert app on your smartphone or sign up online at [www.emergencyalert.alberta.ca/content/about/signup.html](http://www.emergencyalert.alberta.ca/content/about/signup.html)
- Create a financial safety net. Review your home insurance, save for emergencies if you can, and always keep a little cash on hand.
- Build your social network. Talk to your neighbours, family and friends about emergency preparedness and how you can share resources.

Emergency preparedness contributes to resiliency and mental well-being. Will you have the ability to bounce back emotionally and financially after a significant event?

**What are Emergency Social Services?**

Emergency social services help people who have been impacted by a major emergency or disaster by providing basic needs to maintain physical, emotional and mental health and dignity. Types of events that could require emergency social services include those that would spur an evacuation order, such as a flood, urban fire, earthquake, tornado, wildfire or a prolonged power outage due to extreme weather conditions. Emergency Social Services are provided by your municipality usually during the first 72 hours after a disaster and are geared to vulnerable folks who don't have financial or social resources.

**What about pets and livestock?**

Making an emergency plan for your pets and/or livestock is also very important. There are some great planning tools here:

- <http://www.alberta.ca/farm-animals-and-livestock-preparedness.aspx>
- <http://www.alberta.ca/pet-preparedness.aspx>

**Crisis and disaster recovery**

If you've been impacted by recent disaster events and

your stress levels have not returned to their regular levels, it might be time to reach out for support. Please contact Kristin to discuss options for counselling support or subsidies at 780-955-6421.

**UPCOMING SESSIONS**

**Reclaiming Our Well-being: Challenging Diet Culture and Nourishing Mental Health**

In a society that bombards us with idealized eating plans, picture-perfect recipes, conflicting nutrition information and unrealistic beauty standards, it's time to reclaim our well-being and challenge the pervasive influence of diet culture. Join us for this workshop where we will dive into how societal norms can impact our mental health and the way we nourish our bodies.

This session will be facilitated by Emily Fentie, Registered Dietitian of The Nourish Collective.

**Time:** noon to 1 p.m.

**Location:** online via Zoom

**Register:** contact Kristin at 780-955-6421 or [kristin@leduc-county.com](mailto:kristin@leduc-county.com).



**June is Alberta Park's & Recreation Month**

*Bob & Rose Oppegaard*  
**50th Anniversary Open House**  
**Thorsby Community Centre**  
**Sunday, July 9th from 2 - 6pm**



**2023 summer camps  
register today!**



**Leduc County summer camps  
are open for registration!**

This summer, all of our registered camps are three days long and run from 9 a.m. to 3 p.m. Our camps offer a great opportunity for children to become more comfortable in different social environments and strengthen connections while working on social skill development.

**Upcoming summer camps include:**

- **July 11 to 13** - Lego Camp at Glen Park Hall
- **July 18 to 20** - Cooking Camp at Rolly View Hall
- **July 25 to 27** - Cooking Camp at Telford Community Hall
- **Aug. 1 to 3** - Sports Camp at the New Sarepta Agriplex
- **Aug. 8 to 10** - Sports Camp at Sunnybrook Hall
- **Aug. 15 to 17** - Lego Camp at Cloverlawn Community Centre

All camps are \$110 per child. For more information and to register, visit [leduc-county.com/recreation](http://leduc-county.com/recreation).



**Celebrating GOD'S Greatness**

**2023 Vacation Bible School**

**July 10 to 14**

**9 - 11:30 am**

**Warburg Alliance  
Church**

**5 yrs to Grade 6**

**FREE**

Join us for games, adventures,  
stories, songs, crafts & snacks

For more information or  
to register call

Eva Hubscher 780-696-2482

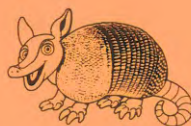

**BREAKING  
NEWS!!**

**PLEASE BE SAFE AROUND  
PUBLIC WORKS EQUIPMENT!**

Please be cautious to not approach Public Works when they are running equipment, and please do not startle them. Equipment sightlines are difficult and even though our crew are well trained professionals, they are not expecting anyone to drive up outside of their sightlines or get out and approach them on foot. Vehicle or bodily damage can occur if they are startled or do not see you, as well as impacts to your insurance.



**Please help them work safe!**

**Thorsby Town Office Regular Hours**

Mon: 8:30am – 4:30pm

Tues: 8:30am – 4:30pm

Weds: 8:30am – 4:30pm

Thurs: 8:30am – 4:30pm

Fri: 8:30am – 4:30pm

Sat-Sun: CLOSED

*The office is now open during Lunch!*

**THORSBY TOWN  
COUNCIL MEETINGS**

**Tuesday, June 27th | Regular | 7 - 8:30pm**

*Next Council Dates to be set at the June 27th,  
2023 Regular.*

*This meeting is **open** to the public, and we  
encourage all Thorsby residents to participate!*

**Town of Thorsby**

4917 Hankin Street, Box 297

Thorsby, AB

TOC 2P0

TEL: 780.789.3935 [www.thorsby.ca](http://www.thorsby.ca)





Thinking of selling?

We have families hoping to buy in this area.

Barrie Cochrane -(780)910-2237  
Leslie Cochrane -(403)866-7275  
pigeonlakeproperties.ca  
loft3design.com

**ROYAL LEPAGE**  
**GATEWAY REALTY INC.**



**FRONTIER**  
**Pallet Forks**  
Available in 42" and 48" Tines.  
Starting at **\$1,249**

Make the most of your land.

➕ Add an Implement to your Compact Tractor!



**FRONTIER**  
**Post Hole Digger**  
Post Hole Auger Bits Sold Separately  
Starting at **\$1,999**



**FRONTIER**  
**Rotary Tiller**  
Available in 49" - 93" widths.  
Starting at **\$3,899**



**FRONTIER**  
**Broadcast Spreader**  
Starting at **\$1,499**



**FRONTIER**  
**Front Loader**  
Mounted Blade  
Available in 5' - 10' widths.  
Starting at **\$2,999**



**FRONTIER**  
**Grooming Mower**  
Starting at **\$5,649**



Call or Text 780.848.7777 | 5704 50 Street, Warburg | martindeerline.com  
See in Store for Details.



# AHS SCREEN TEST IN THORSBY!

## Bringing good breast health to you

The AHS Screen Test Mobile Mammography Clinic will be returning to **Thorsby August 11, 2023**. Screen Test brings breast cancer screening to clients across Alberta with its state-of-the-art mobile mammography unit. Thank you for supporting Screen Test over the past 30 years. It has been our pleasure bringing screening mammography to you. Together we are saving lives, one community at a time.

We are asking for your help to raise awareness about the clinic and the importance of breast cancer screening. Here are some ideas about raising awareness:

- Share the attached e-poster on Facebook and online community groups, forward to your colleagues, friends and individuals who may be eligible (age 40+). A PDF and JPG are included for your convenience.
- To order other resources please fill the attached resource order form and fax or email [screen.test@ahs.ca](mailto:screen.test@ahs.ca)
- Visit the [www.screeningforlife.ca](http://www.screeningforlife.ca) website for breast health and Screen Test information
- Tweet about it – share this tweet “Did you know that mammogram saves lives? The Screen Test mobile mammogram clinic will be in Thorsby August 11. Call 1-800-667-0604 (toll-free) today to book an appointment!”

## Here’s some info about the clinic:

**What:** AHS Screen Test Mobile Mammography Clinic

**How to book:** Call 1-800-667-0604 (toll-free)

**Cost:** None

## Who should be screened?

- **Women 45 to 74:** This group is most commonly diagnosed with breast cancer, and should plan to have a mammogram every 2 years until they turn 75. This group can self-refer.
- **Women 40 to 44:** Screening is optional and they should discuss the risks and benefits of screening with their health care provider. A referral is needed for their first mammogram in Alberta, which is available online here.

[www.albertahealthservices.ca/frm-20078.pdf](http://www.albertahealthservices.ca/frm-20078.pdf)

- **Women 75 and over:** Can continue screening and should discuss the risks and benefits with their health care provider.
- **Screening mammograms are not recommended for those under age 40:** Talk to your health care provider if concerned about having an increased risk of breast cancer.

## TRANSGENDER, GENDER DIVERSE AND NON-BINARY PEOPLE ELIGIBLE FOR SCREENING:

- Assigned female at birth and have not undergone top surgery (mastectomy), or
- Assigned male at birth and have been on feminizing hormone therapy for 5+ years in total.

**Why are mammograms important?** Screening mammograms are routine tests used to find early signs of cancer in individuals who have no breast problems or symptoms. They can find changes in the breast that are too small to be felt. Early detection with mammograms is one of the reasons that most women (89%) are now surviving breast cancer. To learn more about Screen Test, visit our [www.screeningforlife.ca/breast/screen-test-mobile-clinics/](http://www.screeningforlife.ca/breast/screen-test-mobile-clinics/) or call us at 1-800-667-0604.



KEEPING YOU COMFORTABLE ALL THROUGH THE YEAR

Furnace & Air Conditioners

**Your Local HVAC Company**

office

**780-637-5339**

cell

**780-964-4390**

[www.actionheatcool.ca](http://www.actionheatcool.ca)

# Darcy Powlik

780-446-9700

[www.darcypowlik.com](http://www.darcypowlik.com)

Office: 780-986-2900



**RE/MAX**  
Real Estate Leduc

## RESIDENTIAL, FARMS & ACREAGES

**CALMAR**- 4 Bedroom, 2 Bath fully finished and recently renovated bungalow with large insulated detached garage with parking pad! (E4321527) ~~\$285,000~~ **PENDING**

**LEDUC COUNTY**- 1400 Sq.Ft House on 70 acres with Riding Arena, Barn, Quonset, Oil Revenue and More! Close to Calmar! (E4303894) **SOLD** \$500,000

**THORSBY** - Gorgeous 12.40 acres backing onto creek/ravine, 1047 Sq.Ft Bungalow, Garage, Barn, Machine/cattle shed **\$399,900.00**

**THORSBY** - 1063 Sq.Ft 1 1/2 Storey with tons of recent renovations, Large fenced yard. **\$199,900.00**

**THORSBY** - 2.97 acres of park like setting on pavement, 1079 Sq.Ft Bungalow with partly finished basement, Double detached garage **\$399,900.00**

**THORSBY** - 1592 Sq.Ft 3 Level split, 4 bedrooms, Large 50'x150 corner lot, 20'x32' Detached shop, Garden spot, RV parking **\$299,000.00**

**THORSBY** - 5 acres on pavement at the entrance to Thorsby. Great place to build **\$195,000.00**

**WARBURG** - 1500Sq.Ft Bungalow on large corner lot, 5 bedrooms, finished basement, detached o/s double garage. **\$279,900.00**

## RAW LAND & VACANT LOTS

**BRAZEAU COUNTY**- 14.93 acres of rolling land which is partially treed. Located on pavement close to Hwy 39. Many great building sites. Room for animals! (E4289275) **\$149,900**

**BRAZEAU COUNTY**- 2 LOTS, 15.05 acres of treed rolling land. 232 meters x 262.50 meters. Great building sites with treed privacy. Very private and quiet. Services are close. Located at the corner of RR 60 and Twp 484. (E4323597)(E4323598) **\$149,000**

**LEDUC COUNTY**- 32.67 acres right at Pigeon Lake, close to Johnsonia & Itaska Beach. Great place to store your toys from the lake. Land can be rented out to local farmers for hay and crop production. Zoned Pigeon Lake Watershed. (E4313307) **\$299,000**

**LEDUC COUNTY**- 73.11 acres of **REDUCED** quality farm land, zoned Agriculture. Located on the corner of RR 272 & Highway 39. Two miles west of Calmar on Hwy 39. Good producing soil. (E4323202) ~~\$575,000~~ **\$549,000**



Children's  
Miracle Network

**MIRACLE  
HOME**  
Contributor

Helping kids at



**"NOBODY SELLS MORE REAL ESTATE IN THIS AREA!"**

# TRUE NORTH TURNROUND



*...He will baptize you with the Holy Spirit & fire. Matt 3:11*



## WHEN

**June 30-July 2 (Fri-Sun)**  
**Evenings— 7 pm (Fri-Sun)**  
**Afternoons— 1 PM (Sat & Sun)**

## WHERE

**48308 RGE RD 281 (Type this into GPS)**  
**(Southeast of Thorsby & north east of Pigeon Lake)**  
**(South of Glen Park Road**  
**TWP Rd 490)**



**FRI 7 pm— Apostle Marty Swanson**  
**SAT 1 pm- Pastor Bob Matthew**  
**SAT 7 pm— Pastor Rodney Fortin**  
**SUN 1 pm— Pastor Gordon Belcourt**  
**SUN 7 pm— Pastor TJ Green**

**BAPTISMS ALL  
WEEKEND**

**RV/TENT/  
CAMPER**

**Outdoor kitchen**

**BBQ on site**

**Wash stations**

**Toilets**

**No hook-ups**

**FOOD**

**Friday Eve— chili,  
hot dogs & buns**

**Sat /Sun Eve-Pot  
Blessing**

**Brekkie & lunch—  
on your own**

**SPONSORS**

**Warburg Salt of the  
Earth Revival Church**

**New Testament Church  
Slave Lake**

**The Harvest**

**CONTACT**

**Pastor Sandy Broadbent**

**780.887.2632**

**Pastor Irene Belcourt**

**780.843.5448**

**Reg McKinney**

**780.919.5770**

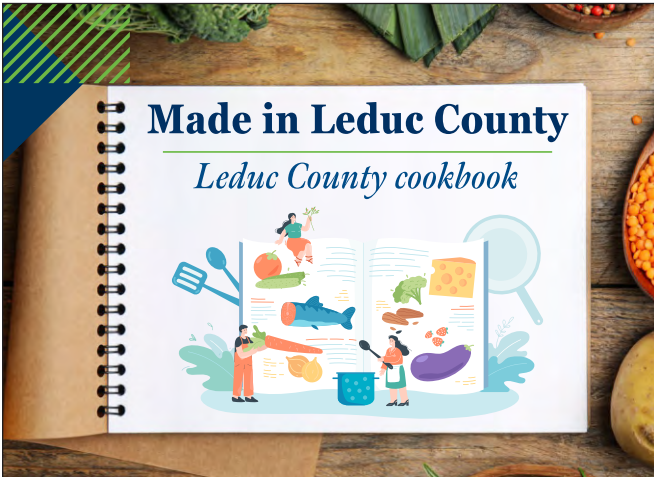

## Made in Leduc County

Leduc County is a proud agricultural community. We have large agricultural producers, smaller local food operations and everything in between! This summer, we are celebrating our love of agriculture and food with a community-made cookbook! Made in Leduc County will feature recipes submitted by you - our residents - and will be shared in fall 2023.

### How to participate

We will be collecting recipes from **June 7 to Aug. 31**. The Made in Leduc County cookbook will be sorted into a variety of categories, as listed below.

- ▶ Beverages
- ▶ Appetizers
- ▶ Soups
- ▶ Salads
- ▶ Vegetables
- ▶ Side dishes
- ▶ Main dishes
- ▶ Breads, loaves, muffins
- ▶ Desserts
- ▶ Other

Submit your recipe online at [www.yoursayeducounty.com](http://www.yoursayeducounty.com). Please include a photo if you have one!



**Dawn Heisler 780-619-2564 (cell)**  
 780-986-2900 (office) [www.dawnheisler.remax.ca](http://www.dawnheisler.remax.ca)  
 email: [dawnheisler@remax.net](mailto:dawnheisler@remax.net)

**RE/MAX** Real Estate  
 Independently Owned and Operated

### BIG AND GRAND

4800 sq.ft. home on double lot in Breton. 3 huge bedrooms,



3.5 baths plus room to expand! Studio/flex/business space with so many possibilities. Heated garage, fenced **E4330229 ~~\$398,000~~ \$374,000!**

### BRETON



3 bed, 2 bath home backing school. Many upgrades. Double garage, fenced, RV parking. Beautifully landscaped. **E4346098 \$195,000**

### THORSBY BUNGALOW



On huge 50x 264 ft. lot. 2 bedroom, newer shingles, vinyl windows. **E4322203 ~~\$130,000~~ \$125,000**

### NEW MOBILE

Never lived in 2 bed, 2 bath in Warburg MHP. Lot rent \$260/month **E4296519 \$135,000**



### THORSBY

3 Bed, 2 bath bungalow, finished basement, many upgrades, large garage **E4339733 \$259,000**



### SECLUDED 4.27 ACRE



5 bed, 3 bath, walkout basement, 32x48' shop, barn **E4318673 ~~\$525,000~~ \$410,000**

### THORSBY

2 bedroom, 2 bathroom bungalow on a massive 100 x 150' lot. Many upgrades including windows, metal roof, siding, HWT, furnace, flooring and more. **E4342617 \$237,500**



### WARBURG VACANT LOTS

Residential Lot 12 **\$24,000 ~~\$20,000~~**  
 Lots 23-25 Your choice **\$45,000 ~~\$40,000~~**  
 2 serviced lots **E4325274 \$20,000** each  
 Commercial 150x110' lot **E4322848 \$49,999**

# WARBURG YOUNG AT HEART QUILTERS

*Submitted by Nancy Gruninger*

Pictured with the many finished quilts that were donated to Breton Victim Services on May 16, 2023. Many hours went into making these charity quilts from fabric generously donated to us, which we really appreciate.

We also donate to Warburg FCSS, the Library for their Christmas draw, and to the Bags of Love for children who are going into foster care.

We meet Tuesday and Thursdays at the Warburg Seniors Centre, from October to May, and always have room for more quilters.

Any questions phone Nancy at 780-848-1156

*(2 members missing in photo)*



*Ms Turner & Mrs. Witteman's group of Grade 7 & 9's cleaning up Thorsby's Lions Club Campground!*

**THORSBY'S  
GRADE 7 & 9'S  
TEAMED UP AND  
CLEANED UP  
THORSBY IN  
RECOGNITION OF  
NATIONAL  
INDIGENOUS  
PEOPLES DAY.**

**AW Auto Body Works**

**Auto Body Repair**  
**NO INSURANCE JOBS**

**Clayton Rumohr & Dale Babiak**  
info.autobodyworks@gmail.com  
780-975-5408

**PLEASE CALL OR TEXT FOR APPOINTMENT**

**Wenham Valley Pet Cremation**

**Geneva Rodin**  
(780)621-3531  
geneva\_rod@hotmail.com

*"Our pets leave footprints on our hearts"*

**Warburg, AB**

# DYCK INSURANCE AGENCY LTD.



Farm specialists – Home Insurance – Auto Insurance – Commercial Insurance – Liability Insurance

“Service is our business”

Supporting the Thorsby area since 1997

**More options**

**More choice**

**More savings**

Support your local Brokerage

Calmar, Thorsby, Wetaskiwin



# Your Say Leduc County

## Public participation website now live

Leduc County knows that an engaged public and effective public participation improves the quality of the decisions we make, so we have now launched Your Say Leduc County.

Your Say Leduc County provides a space for County citizens to give their input on projects and share ideas for the future. The website features integrated tools strategically selected for each project. These tools include surveys, forums, polls, ideation walls, mapping tools, question-and-answer modules and more.

## About public participation

While there are many different terms for public participation that are used interchangeably – including community engagement, public engagement, P2 and public consultation – they all mean the same thing. At Leduc County, we use the term “public participation.”

**Public participation** is any process that involves participants – external participants such as residents, business owners and community groups and/or internal participants such as staff – in problem solving or decision making and uses their input to make decisions.

## Have your say

Register with Your Say Leduc County to stay involved in your community and provide input on key projects and decisions, visit [www.yoursayleduccounty.com](http://www.yoursayleduccounty.com).



► Register with **Your Say Leduc County** by **Aug. 7** for a chance to win an iPad!



# WARBURG SEED CLEANING CO-OP LTD.



Phone No. 780-848-2365

[warscp@gmail.com](mailto:warscp@gmail.com)

[www.warburgseed.com](http://www.warburgseed.com)

“like us” on Facebook

Hours: 8:00 am to 4:30 pm Mon to Fri

*Cleaning services for various seed varieties*

*90 ft. scale*

*Bagged food grade wheat, Bagged Hulless barley available for soups, stews, etc.*

*Various varieties of bagged & bulk feed - rolled or whole. We only sell what we clean here and don't add supplements, etc. Our rolled mixes include 40-30-30 (40% wheat, 30% barley & 30% peas) & 50/50 barley/oats or make up your own custom mix.*

*Our 40-30-30 mix is used to feed a variety of animals & birds including wild birds*

*Need a tote bag... we have small & large tote bags for sale*

*Black oil sunflower seeds*

*Flax*

*Various sizes of tarps, straps & accessories in stock or we can order what you need. We can also order greenhouse plastic.*

*Lawn seed & lawn & garden fertilizer*

*Nitrogen & PowerRich fertilizer & bagged forage seed*

*Various varieties of Pedigreed seed available*

*Retailer for Proven Seed, Inland Plastics, Union Forage (swath grazing) & PowerRich Fertilizer*

# CONTINUOUS MASKING NO LONGER REQUIRED IN AHS FACILITIES

EDMONTON — After careful review, Alberta Health Services (AHS) has rescinded continuous masking requirements. As of June 19, 2023, AHS will no longer require continuous masking at all AHS facilities, including Continuing Care and contracted sites.

This applies to all patients, families, and visitors at AHS facilities, as well as Alberta Precision Laboratories, Covenant Health, CapitalCare, and Carewest sites. It also applies to all AHS and contracted staff, including physicians, midwives, students, volunteers, and contractors.

The decision to rescind the current requirement for continuous masking was made based on a number of factors, including declining COVID-19 cases, testing positivity rate, wastewater data and hospital admission rates for respiratory illnesses in Alberta, as well as consultation with stakeholders including patients, families, advisory councils, clinicians and frontline managers.

AHS continues to respect the choice to voluntarily wear a mask in all areas and encourages those who want to wear a mask to continue to wear one. In addition, patients are encouraged to have conversations with their care providers regarding masking, hand hygiene, or other factors that patients feel are important to their care.

AHS continues to encourage visitors or designated family support persons who have had respiratory symptoms to wait to visit loved ones until 10 days after symptom onset, and all visitors and support persons are recommended to mask when visiting symptomatic patients or residents.

Staff are required to continue to use the Infection Prevention and Control Risk Assessment to make personal protective equipment (PPE) decisions and AHS Routine Practices to prevent the spread of infections.

Appropriate types of masks and PPE will continue to be available in all settings for patients and healthcare workers. For more information please refer to the updated FAQ.

As always, all staff are encouraged to stay home when ill and, to continue to practice good hand hygiene as part of our ongoing efforts to keep patients, families and each other safe and healthy.

AHS is committed to providing a safe and healthy environment and will continue to closely monitor the need for changes to masking requirements.

Alberta Health Services is the provincial health authority responsible for planning and delivering health supports and services for more than four million adults and children living in Alberta. Our mission is to provide a patient-focused, quality health system that is accessible and sustainable for all Albertans. Our current focus is on reducing emergency department wait-times, improving EMS response times, increasing access to surgeries, and improving patient flow.



**Banman Westerlund LLP**

Chartered Professional Accountants

- Derek W. Banman CPA, CA - Partner
- Kyle Westerlund CPA, CA - Partner

Box 367, 5012 - 50 Avenue  
Breton, AB T0C 0P0

E: [dbanman@banwest.ca](mailto:dbanman@banwest.ca)

#401, 9426 - 51 Avenue NW  
Edmonton, Alberta T6E 5A6

T: 780.696-2511

F: 780.696.2017

T: 780.426.3943

F: 780.424.1875

**SUMMERS  
DRILLING** LTD.

Water well drilling and service  
Family owned Business Serving Alberta since 1917

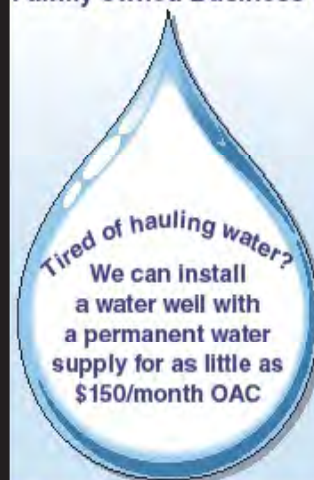

Never run out  
of water again!

5 year workmanship  
warranty

3 Convenient  
ways to pay

- Visa
- Mastercard
- We now offer full financing

Stop in at our office 4405 - 50 Street, Stony Plain  
780-963-1282  
[admin@summersdrilling.com](mailto:admin@summersdrilling.com)



# TALL PINE POWERSPORT SUPPLY

## Parts - Accessories - Service

- ATV's
- UTV's
- SLEDS

- BIKES
- SMALL ENGINES

- OUTDOOR POWER EQUIPMENT



4916 Hankin Street, Thorsby

780.788.5459



Excavation & Skidsteer Services

- Mini Hoe
- Skidsteer
- Gravel Truck
- Landscaping Materials
- Water, Gas & Electrical Lines
- Shop Pads & Driveways
- and more...

Call Warren @ 780-232-9937

WCB covered & insured  
Locally owned & operated



825-461-9666  
bbreeze.janeapp.com

1228 TWP RD 474

## Farmhouse Acupuncture

- Precision Acupuncture for Chronic Pain.
- Therapeutic Massage. Direct billing.

**Dr. Wang Wang (MD. PhD.)**

RAC; RMT; Herbalist 20+ years' experience  
*Specialized in soft tissue chronic pain.*

## Breton Denture Centre

5012 - 50 Ave. Breton

780-696-9696

### Our Services Include:

- Free Consultations
- Same Day Relines
- Complete & Partial Dentures
- 1 Hour Denture Repairs
- Dental Assistance for Seniors
- Referral to a Dentist or Surgeon



**Join Us Again in Completing that Beautiful Smile!**

# UNRESERVED ACREAGE SALE

**Rae Braden-Parkin**  
47415 RD 31, Warburg, AB

**Saturday, June 24, 2023**

**Time: 10:00 a.m.**

Being from the junction of Secondary 771 & 616 go 1¼ miles south on Range Road 31.

Watch for signs

GST will be charged where applicable

Lunch Available



### Trucks

- 2011 Chev 3500 HD 1-ton c/w Western truck body, mechanics tool body c/w 3203 PRX auto crane lift, Airworks air comp. c/w gas eng, Vortec eng, auto, air, 158,937 km, S/N 1GB3KZC60BF183618
- 2016 Dodge Ram 1500 ½-ton Crew Cab, 4x4, Eco diesel, auto, air, running boards, Tono cover, approx. 350,000 km, S/N 1C6RR7GM4GS321589
- 2005 Dodge 3500 1-ton Crew Cab, 4x4, Cummins diesel, auto, air, front winch c/w 8' deck & 5th wheel hitch, new engine in 2009, approx. 450,000 km, S/N 3D7LS38C35G774890
- 1995 Freightliner FL 70 Single Axle c/w 8'x18' deck, 5th wheel hitch, diesel eng, 6-sp trans, 11R 22.5 rubber, 230,415 km, S/N 1FV6HFAB35L545704

### Trailers & Quad

- Atomic 13 Model S3141 Single Axle Alum Skidoo Trailer c/w tilt deck, S/N 5KTS51416DA642232
- Suzuki 250 Quad, runner, 1798 km showing

### Buildings

- 6'x8' Insulated Shed; Two 10x20 Sheds c/w skids, plywood sides, asphalt shingles; 8'x24' Insulated Reefer Van Body c/w back & side doors, diesel eng. controlled

### Mechanic Tools

- Westward SHD 12 Drawer Tool Chest c/w rollers
- 8'x24 Drawer Tool Chest
- Jet 7 Drawer Tool Box
- Snap-On ¾" Torque Wrench
- Snap-On Openend Wrenches, metric & standard
- Snap-On Allen Wrenches
- Snap-On Screwdrivers
- Snap-On Lead Hammers
- Snap-On Ezze-Outs
- Snap-On Socket Sets
- Snap-On Air Hammer
- ¾-1½-3/8 Air Impacts; Assort Hammers; Punches; Chisels; Pry Bars; Drill Bits; Pipe Wrenches; 1"-3/4" Impact Sockets; Metric & Standard Swivel Sockets; Ratchets; Crescents; Pullers; Snap-On Visual; Calipers; many more brand name tools

### Taxidermy Equipment

Mount Forms; Hide Tumbler; Brine Tub, Hide Meat Stripper Wheel c/w table

### Household

Chesterfield & Loveseat; New Bread Maker; Air Fryer; Pressure Canners; Pots; Pans; LCD Projector c/w screen; Christmas Decorations; Pictures; Vacuum Packer; 2 New Air Heaters

### Miscellaneous

Portable Air Comp c/w Honda motor; Electric Air Comp; 2-Ton Engine Jack; JD 3-point hitch 5' Spring Tooth Cult c/w mounted harrow; Red Rock 3' Disc c/w transport; Trailer Hyd. Wood Splitter c/w gas motor; 8'x40' Oilfield Float; Bundle 4"x7' Treated Posts; HD Pallet Fork, (backhoe or wheel loader); Assort. 33' Used Gal Tin; 4'x8' Steel Table; 5'x5' Steel Top Table; Meat Saw; Commercial Meat Slicer; Commercial 3" Meat Grinder; Stainless Pans; Stainless Sink; Golden Eye Radio Control Helicopter, new; New Autel Robotics Drone; 3 - X Pro Drones; Trail Cameras; Estate Sprayer c/w 25-gal. tank; 5' Quad Blade; 2 Harrows c/w drawbar; 100-gal. Tidy Tank c/w 12V pump; 500-gal. Tank c/w stand; 4'x8' Picnic Table; Scaffolding; Plumber Torch c/w bottles; Conibear Traps; Quad Tires; Ridgid Shop Vac; Assort. HD Bearings; Parts; Bolts; Screws; Brass; Assort. Hitches; Electric Tools; Cordless Tools; Grease Guns; Transit; Hunting Blind; Assort. Used Batteries; Garden Cult; Alum. Ladders; Argo Tracks; many more items

### Auctioneer's Note

Lots of good items on this Sale. Take note of the Service Truck & Tools; Viewing is by appointment only. For more information call Rae Braden-Parkin at 780-236-0030 or Miller's Auction Service at 780-789-2226 or 780-920-6738.

[www.millersauctionservice.com](http://www.millersauctionservice.com)

This list is subject to additions or deletions.  
TERMS: Cash, certified check, bank draft, or bank letter of credit, E-Transfer, Mastercard and Visa (3% usage fee on M/C & Visa). No purchases to be removed until settlement has been made. NSF checks will result in criminal charges and prosecution. All sale are final, and all items purchased become the responsibility of the buyer once they are declared sold, and owners and auctioneer(s) are absolved of further responsibility. The above listing is a guide only, and while every effort has been made to ensure accuracy of description, it is not offered as an implied or actual warranty or guarantee as to condition or age. All items sold as is, where is. If it should happen that two bidders have identical bids on an item declared "sold", the bidding will be reopened between those bidders only. The owner(s) and auctioneer(s) shall not be held responsible for any loss or accident on or off the auction site on sale day.

**Owner: Rae Braden-Parkin**  
Phone 780-236-0030

Taylor Printing, Wetaskiwin



**License No. 200809**  
**Box 71, Sunnybrook, AB**  
ALVIN MILLER (780) 789-2226 or Cell. 920-6738  
TREVOR MILLER (780) 722-2705  
BARRY KASHA (780) 374-2472  
Camrose, Daysland, Killam, Tofield, Holden  
DARCY SHEETS (780) 336-6485  
Kingman, Rosalind, Viking  
Clerk: Judy Bentley  
"For Reasonable Rates and Excellent,  
Friendly Service, Give Us A Call"

# Zamek Construction

Pigeon lake and Area

**780-913-0728**

**edjpas@gmail.com**

CHAINLINK FENCING, WOOD, DECKS, PATIOS,  
PREFAB METAL STRUCTURES ASSEMBLED



Installs & Repair  
Renovations  
Private & Commercial



If our oil and gas came with a label you would learn responsible production is in our DNA.

You would also learn Alberta is a leader in many other ways. We know we need to reduce emissions, so we make significant investments in innovation. We also know oil and gas will be required for decades to come. That's why we continue to excel in environmental performance, regulatory quality and human rights. Our commitment to reconciliation is bringing real economic opportunity to our Indigenous partners. And we can help bring LNG – a cleaner-burning fuel – to the world. Explore our label to learn more at [MadeTheCanadianWay.ca](https://www.madethecanadianway.ca)



Global Leader  
Innovation Driven  
Responsibly Produced

**Canadian  
Energy Centre**

**FOR SALE**

20304 - 109<sup>TH</sup> AVENUE | EDMONTON, AB



**CONDO UNITS IDEAL FOR BOAT/RV STORAGE**



**EXCELLENT NORTHWEST EDMONTON LOCATION**

**SIZES RANGING FROM 763 SF - 1,935 SF**

**IDEAL FOR BOAT AND RV STORAGE**

**AVAILABLE JUNE 2023**

**TYPICAL UNIT**

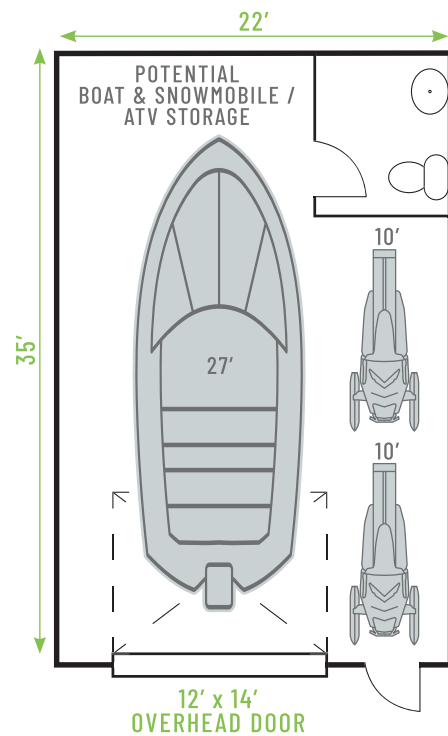

GREGG MAIMANN  
Senior Vice President  
+1 780 917 4632  
gregg.maimann@cbre.com

JAY OLMSTEAD  
Sales Representative  
+1 780 554 1191  
jay.olmstead@cbre.com



# NOW OPEN The TYRE Shop

5004 51 Street Warburg

Services offered:

✓ Tire SALES

✓ Mount and Balance

✓ Tire Repairs

✓ Windshields

Call: 780-848-TYRE (8973)

Open Monday thru Friday 8am to 4:30pm

[www.thetyreshop.ca](http://www.thetyreshop.ca)

ROYAL LEPAGE  
GATEWAY REALTY INC.  
Independently Owned & Operated

View My Listings at  
[macrae-sells.ca](http://macrae-sells.ca)

**ROBERT MACRAE**

780-991-9939

[number1seller@shaw.ca](mailto:number1seller@shaw.ca)

did you  
**know** ?

The largest eggs in the  
world are laid by a shark

**HP** Electric Inc. 

Residential - Commercial - Farm  
Trenching - Scissor Lift

Blair Hennes

780-686-0418

Curtis Peck

780-278-7614

[hpelectricinc@gmail.com](mailto:hpelectricinc@gmail.com)

## Pre-Harvest Machinery Consignment Auction

Rimby, Alberta - Online Auctions - Toll Free 1-855-783-0556

**AUGUST 18TH TO 22ND, 2023**

Rimby Sales Yard - 3940 50th Ave

Selling equipment to all four Western provinces and the Northern USA. Listings are now being accepted for our Pre-Harvest Machinery Consignment Auctions at our Rimby Sales Yard Location

Phone: (403) 843-2747 Office - Allen B. Olson - (403) 783-0556 - Justin Janke - (780) 515-0888

We are now accepting Listings for this Sale. Any items prelisted by July 20th will be included in our Sales Posters, Newspaper & Radio Advertising, Web Page, Social Media and extensive mailing lists.



## Allen B. Olson Auction Service Ltd.

Rimby Office - 403-843-2747 - Toll Free - 1-855-783-0556

Hwy #16 East Office - 780-208-2508

Rimby & Hwy #16 East, Alberta - License No. 165690

Email: [abolson@telusplanet.net](mailto:abolson@telusplanet.net) - Website: [www.allenolsonauction.com](http://www.allenolsonauction.com)



## BRETON TIRES AND TOW

*For all of your tires, towing, parts, accessories, and windshield needs!*

*We have vehicle, recreation, implement, and trailer tires!*

*Standing tall in Community, Service and Reliability.*

Open Mon-Fri 8-4:30

780-696-3757

Towing 24/7

[bretontiresandtow@gmail.com](mailto:bretontiresandtow@gmail.com)



49019 Range Road 22, Sunnybrook, AB

We Repair:

- Truck Transport • Industrial • Heavy Equipment •
- Agriculture • Automotive • School Buses •

780.789.3322 1.855.789.3322

[www.nitronut.com](http://www.nitronut.com)

Check out our Facebook page!

## BILAR'S GARAGE LTD.

SPECIALIZING IN MAINTENANCE AND REPAIR OF NEW & OLDER VEHICLES IN THORSBY SINCE 1936



# FREE

*Front end and braking system inspection*



**Come in for your Oil Change & 50 Point Inspection**

780-789-3661



## NIGHT HAWK AUTO

Division of 

**Complete Automotive Service & Repair On All Makes and Models**

*"Friendly & honest service, with a mechanic you can talk to."*

### SERVICES OFFERED INCLUDE

- Out of Province Inspections • Automotive Repair
- Tire Service • Wheel Alignments • Diagnostics
- Hydraulic Hose Repairs • A/C Service and Repair
- 50 Point Inspection with Oil Changes
- Minor Welding Repairs • Part Sales
- Fleet Maintenance Programs

**OUR SHOP WILL BE CLOSED JUNE 19 - 23**

*We apologize for any inconvenience!*



780.789.4159

[nighthawkautomotive@gmail.com](mailto:nighthawkautomotive@gmail.com)



LOCATED 2 miles south of Thorsby & west 1/2 mile to 1248 TWP Rd 490

## JAW'S Backhoe Service Ltd.

780-898-2512



### BACKHOE FOR HIRE

Reasonable rates. Fully insured.

Specializing in excavation, compaction, trenching, installation of septic systems, water lines, utility lines, footings, culverts, integrity digs, cattle guards, garage pads

**For all your excavation needs call Jody at 780-898-2512**



# HOUSE FOR SALE

Estate Home of Carolyn and Richard Hoffman

Park Like Setting - Best Location in Thorsby

Huge Lot - Creek Out Back

**ONLY \$339,000**

3200sqft of Finished Living Space.....(1650sqft Main Level plus 1560sqft Walk Out Basement)



**\*\*REALTORS  
WELCOME**



This amazing Ranch style house with an amazing deck and incredible views is located on the most desirable lot in Thorsby. The house is set on a massive double lot and is adjacent to a protected park reserve that creates a 2 acre plus park-like setting. Enjoy an evening drink on the massive maintenance free deck while watching the sun go down over the horizon to the west.

The yard is fully landscaped with several stone rearing wall features and is easy to care for.

Inside you will find 3 bedrooms and 1.5 baths on the main floor and another large bedroom and a full bathroom on the lower level. The home has received many upgrades and renovations over the years and has an amazing comfort about it.

Natural light pours in from the many windows and the layout is very open and expansive.

An oversized attached garage (24x30) is insulated and finished inside and it has its own furnace. The garage is well lit and has air lines running throughout for your convenience.

The size and location of this property as well as the many upgrades that are included in this house will give you a tremendous value for your dollar. It is rare a house of this quality and location comes up for sale.

- 4 bedroom
- 2-1/2 bath
- 24 x 30 Attached Garage
- Central Air Conditioning
- High Efficiency Furnace
- Newer Hot water tank
- Hardwood Floors
- Ceramic Tile
- Carpet in Basement

**Special Features:**

- Modern Claw foot soaker tub
- Glass walled shower
- Bar & large recreation room
- Pool table
- and much more

**Call now to set up a viewing. Geoff 778.214.6507**

# Laurie's Laughs

In Memory of



**Always make sure  
SOMEONE in the  
relationship has good  
credit. That's why it's  
called SIGNIFICANT other.  
Sign/if/I/can't.**

**Follow me for more  
marriage tips.**

**It takes time to learn how  
to play hide and seek**



**For most people  
when you lose your  
"khakis" you've lost  
your pants. When  
you're from Boston &  
lose your "khakis"  
you can't start your  
car.**



**Once I went to a party with my  
husband, full of people he knew  
(from work) but I didn't. A guy  
came up to us, turned to me and  
said "You must be his wife." I  
turned to my husband and said  
"You have a WIFE?" Should've  
seen the guy's face!**

1	4			9			5
		8			4		7
			3		1	8	
	5		4				
6				3	9	7	
	9		1			3	
		6	2				
9				8			
4			1		8		

*Answers will be published in the next issue!*

# Genesee Agricultural Society

## PUMPKIN FESTIVAL

*is coming back on September 30!*

Pancake Breakfast

Hay rides

Market  
(limited space for vendors)



Children's Games

Live Music

and more...

**ENTER YOUR PRIZE PUMPKIN, SUNFLOWER, VEGETABLE OR BAKING!**

*Winners for Heaviest Pumpkin, Tallest Sunflower, Sunflower Biggest Head, Carved Pumpkin, Oddest Shape Pumpkin, Most Perfect Pumpkin, Smallest Pumpkin, Biggest Carrots, Beets & Potato, Best Cookies, Pies, Muffins & Bread!*

For more information contact Joanne 780-940-7229

### Zone Out Sound Healing Community Sound Bath

**June 28th  
7-8pm**

at the Royal Canadian Legion  
Warburg Branch 205

*Ages 5 and up. Wear comfortable clothing. Bring a pillow, blanket and yoga mat. Chairs are provided for those who prefer to sit.*

**Walk-ins welcome**

Buy one admission and bring a friend for **FREE**

Admission \$20

For reservations or more information call or text Sheri @ 778-694-9875

CLAYTON SWAN, B.A. M.A. J.D.  
BARRISTER & SOLICITOR



☎ (+1) (825) 322 2500  
☎ (+1) (825) 322 2501  
✉ frontdesk@w5law.ca  
🌐 www.w5law.ca  
📍 5120 51 Ave, Warburg, AB T0C 2T0  
📦 Box 400 Warburg, Alberta T0C 2T0

Innovative. Local. Affordable. Available.

General practice law firm located in Warburg for all your legal needs, including but not limited to:

- Criminal Law
- Corporate Law
- Estate Planning and Administration
- Family Law
- Real Estate
- Notary Public

Call, email or visit our website to make an appointment

**FOR SALE**



**780-696-2249**

# www.MooresRealty.ca

An entire team of REALTORS® working for you  
Trent Wirsig, Terence Barg, Justin Hatt, Cathy Hatt

For more info on these & other properties visit our website at [MooresRealty.ca](http://MooresRealty.ca)



**BRETON**  
132 Willow Drive - 2015 SRI mfg 3 bed 2 bath home on its own lot in Breton with room for a garage. West facing deck. Concrete drive.  
**\$165,000**



**TOMAHAWK**  
Opportunity! 2 duplexes on 1.5 acres. 3 units currently rented. Larger 4th unit freshly reno'ed & ready for tenant or you.  
**\$345,000**

**LOTS IN BRETON**  
at  
**DEER CROSSING ESTATES**  
2 lots still available. No time requirement to build, GST included in price. Village will put in driveway. \$45,000/lot



**BRETON**  
12 Fraser Drive - large lot backs onto golf course - 159 ft golf course frontage. No time restrictions to build. GST included.  
**\$49,900**



**LODGEPOLE**  
60x130 lot. Natural gas & drilled well on property. Power & sewer at lot line. Zoned Hamlet Residential. Mfg homes permitted.  
**\$25,000**



**BUCK LAKE**  
410 Lakeshore Dr. Business or Pleasure or both. 0.66 acre commercially zoned lot with home on raised basement, shed.  
**\$185,000**



**BUCK LAKE**  
Buck Lake Estates - Lakefront - 5 bed 3 bath home, walkout basement. Triple att garage. Heated shop. Remote control gate & more  
**\$949,990**



**BUCK LAKE**  
West Point Beach - 1 bed 1 bath cabin built 1988, 0.8 acre lot. Wood stove, full kitchen, Drilled well, 2000 gal septic tank & power  
**\$190,000**



**BUCK LAKE**  
Greystones - 3 bedroom, 2 bath custom built home, 26x56 garage with bonus room, paving stone firepit area... and more  
**\$550,000**



**BUCK LAKE**  
Willowhaven - 0.59 acre lakefront lot (environmental reserve), 2004 mfg home, heated garage, seacan, storage shed, 90' dock  
**\$385,000**

## LAND

**INVESTMENT OPPORTUNITY**  
8 quarters (1267 acres), spacious home, 32x40 heated shop, Quonset, 2 waterers. 2nd serviced yard site is on the quarter to south. Substantial annual revenues received from surface leases & land rent. On Hwy 22. short distance to Drayton Valley \$6,500,000

**TREED GETAWAY**  
155.64 Acres backing onto crown land Gravel area partially chain link fenced Power with RV plugin. Trails thru trees, deep ravine, wildlife. Winfield \$475,000

**SCENIC with POWER & WELL**  
79.5 ACRES with approx 50 acres of hay. Balance in pasture. Power & Well. \$2855 annual surface lease revenue. BUCK CREEK \$299,000



**BUCK LAKE**  
Buck Lake Getaway - 100x100 lot, older 3 bedroom mobile home, 1 bedroom cabin, 24x24 older garage. Artesian well. Power  
**\$91,300**



**BUCK LAKE**  
GREYSTONES Lakeview 1.13 acre, services - power, well, nat gas riser. 40 ft Jayco RV with 3 slides. Shed.  
**\$169,000**



**WINFIELD**  
158 acres, creek, mature forest, cabin, peace & tranquility! East Poplar Creek flows thru this land. on no exit road.  
**\$949,000**



**BUCK LAKE**  
Buck Lake Estates 0.54 acre Lakefront, lakeview, 4 bed home, walk-out basement. 3 car heated garage. Also a single car garage.  
**\$649,000**



**BRETON**  
Eye catching A-Frame home with second floor loft The open concept living/dining/kitchen with vaulted ceilings and loads of natural light from windows. Two bedrooms, 2 bath Shed, gazebo & firepit incl.  
**\$248,000**



**WINFIELD LIQUOR LOFT**  
Opportunity knocks in the community of Winfield, Alberta. Be your own boss of this Liquor Store. The Winfield Liquor Loft has been serving the community and surrounding areas for 10+ years. Built in 2011, this solid built 1152 sq ft building has a metal clad exterior & covered front sidewalk running along the front of the store. Inside is the attractive front & cold room retail spaces, storage space, off loading double doors and outside metal security gate. Inventory not included in list price. The buyer will have to obtain their own liquor license from AGLC as the current liquor license cannot be transferred.

## OUR TEAM OF REALTORS

Trent Wirsig 780-202-0140  
Terence Barg 780-621-6767  
Justin Hatt 780-621-3695  
Cathy Hatt 780-898-0729

Moore's Agri-Trade Ltd, Breton, AB 780-696-2249

# Rural Real Estate